



CINCINNATI MINE MACHINERY Co.
DA-434, 515, 550, 615 CONVEYOR CHAINS
 MAINTENANCE & INSTALLATION INSTRUCTIONS



WARNING

NEVER INVERT FLIGHTS



INVERTED FLIGHTS WILL NOT SIT FLUSH ON DECK

WE OFFER SCRAPER FLIGHTS
 TO USE AS DECK CLEANERS
 *CALL FOR PART NUMBERS:
 1-800-543-4607

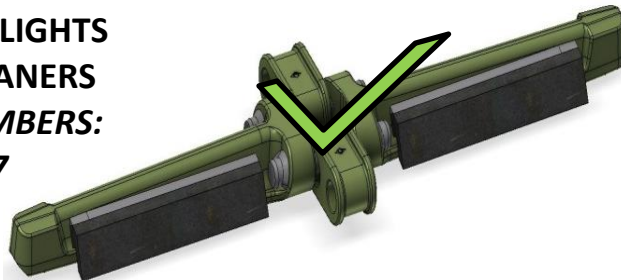

Visit www.cinmine.com For More Information



CINCINNATI MINE MACHINERY Co.
DA-434, 515, 550, 615 CONVEYOR CHAINS
 TENSIONING & INSTALLATION INSTRUCTIONS



WARNING

DEFINITION OF PROPERLY TENSIONED CHAIN
THE LEAST AMOUNT OF TENSION THAT KEEPS
THE CHAIN ON THE SPROCKETS & OUT OF THE
CLA'S AT ALL TIMES

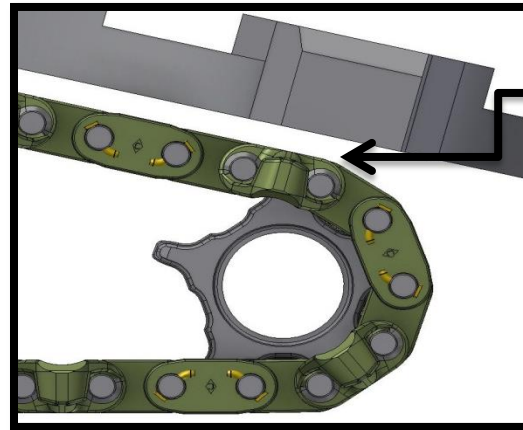

NOTICE

IF TENSIONED PROPERLY
CHAIN SHOULD NOT HIT
CLA'S WHEN CONVEYOR
IS RUNNING

INDICATOR: WHEN BOOM IS STRAIGHT YOU SHOULD BE
 ABLE TO ROTATE FLIGHTS BY HAND NO MORE THAN 2" INCH

2" OR LESS

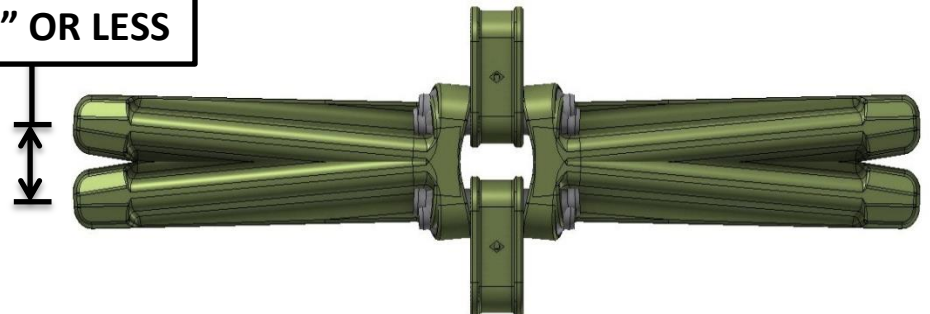

Visit www.cinmine.com For More Information