

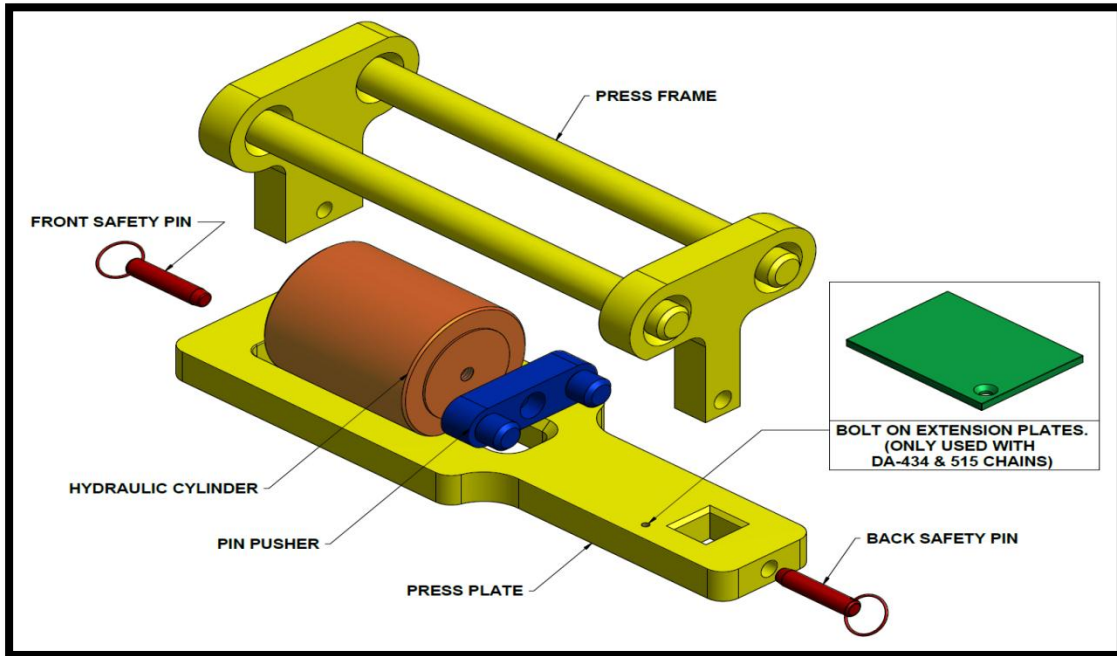

The Cincinnati Mine Machinery Co.

C-14731 – 434/515/550/615 Chain Press – Operating Instructions



TO DISASSEMBLE CHAIN

Remove T-Pins on side of chain that is to be pressed. Place chain over top of Press Plate and cover with Press Frame. Make sure to insert Safety Pins in front and back of press. Pressurize the cylinder to press the chain pins through side strap. Retract cylinder and remove Press Frame.

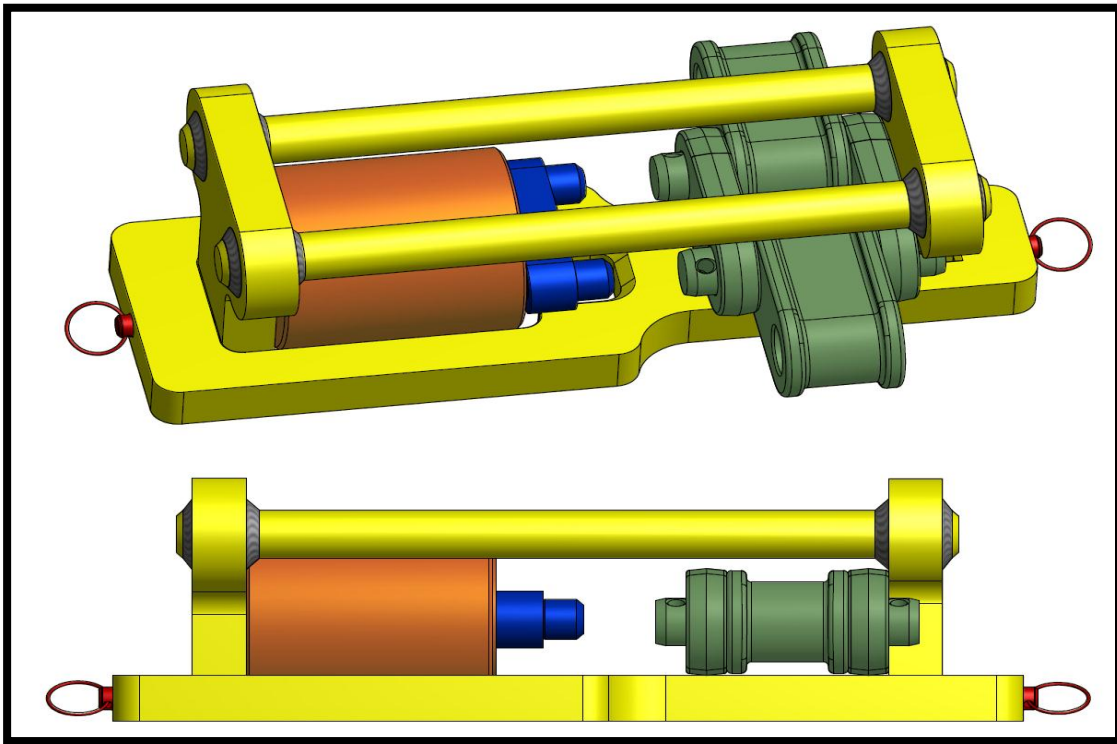

WARNING: Always wear safety glasses, gloves, and other protective clothing when using chain press. Due to the nature of pressing operations, metal chips can break off during pressing operation if not aligned correctly. The Cincinnati Mine Machinery Co. will not be held responsible for any injuries caused during the use of the chain press. Pin alignment is critical for your safety and the safety of your co-workers.



TO ASSEMBLE CHAIN

Place chain over top Press Plate as shown below, and cover with Press Frame. Insert front and back Safety Pins and pressurize the cylinder to press the chain pins through the side strap. The back end of the Press Frame is used as the stop to press together. Press chain together until T-Pin holes are clear for installing the T-Pins. Retract cylinder and remove press. Install T-Pins and bend ends so they cannot slide back out of holes.

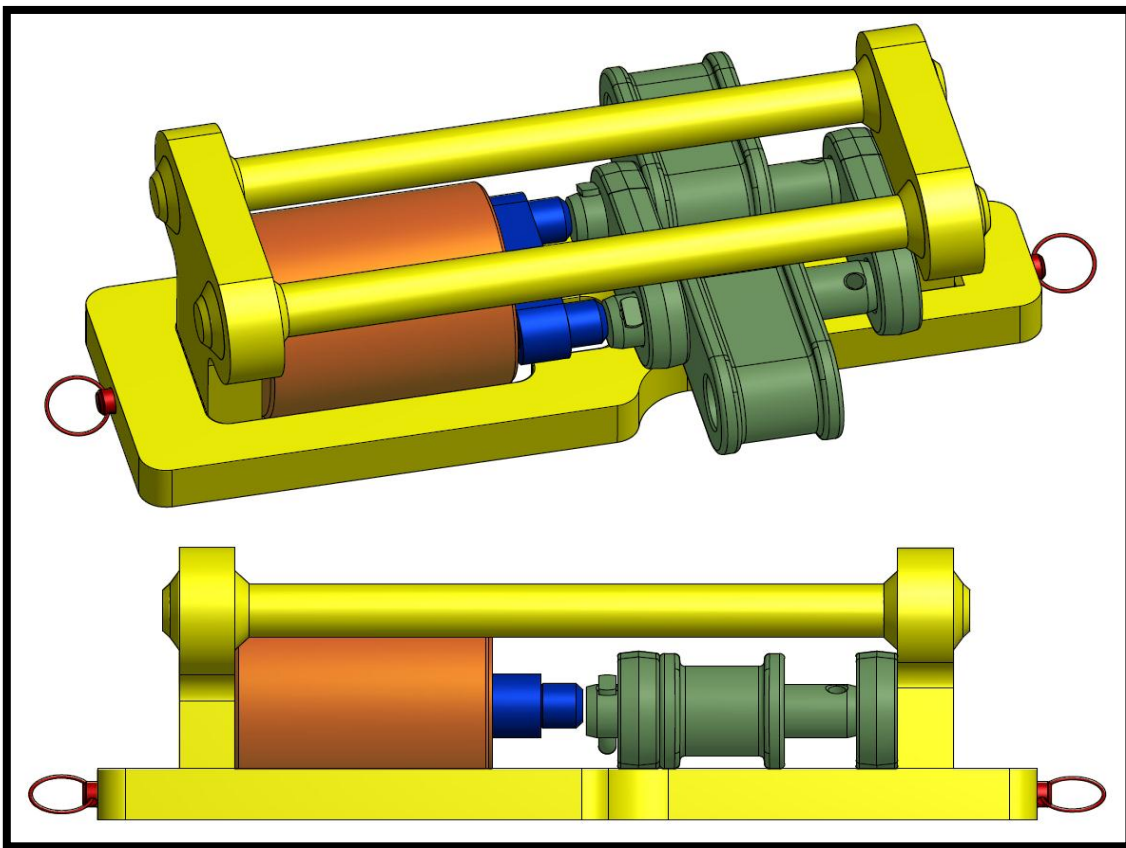

WARNING: Always wear safety glasses, gloves, and other protective clothing when using chain press. Due to the nature of pressing operations, metal chips can break off during pressing operation if not aligned correctly. The Cincinnati Mine Machinery Co. will not be held responsible for any injuries caused during the use of the chain press. Pin alignment is critical for your safety and the safety of your co-workers.
