

DA-515 CONVEYOR CHAIN

The DA-515 series chain is the strongest conveyor chain on the market today. The DA-515 chain is designed to run on a 5 tooth sprocket in most applications for quieter performance. The DA-515 is widely used in coal, potash, rock, limestone, and gypsum mining.

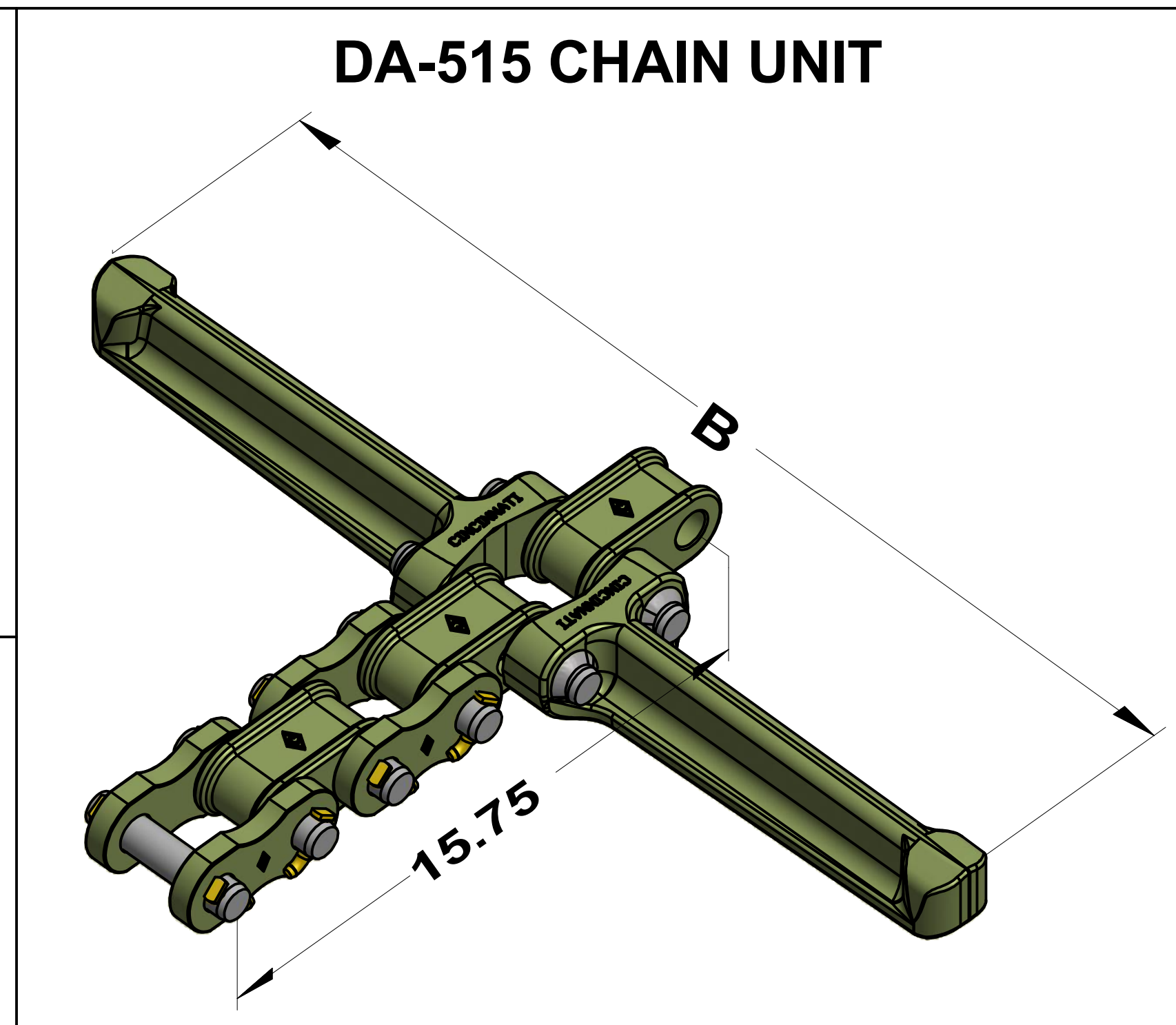
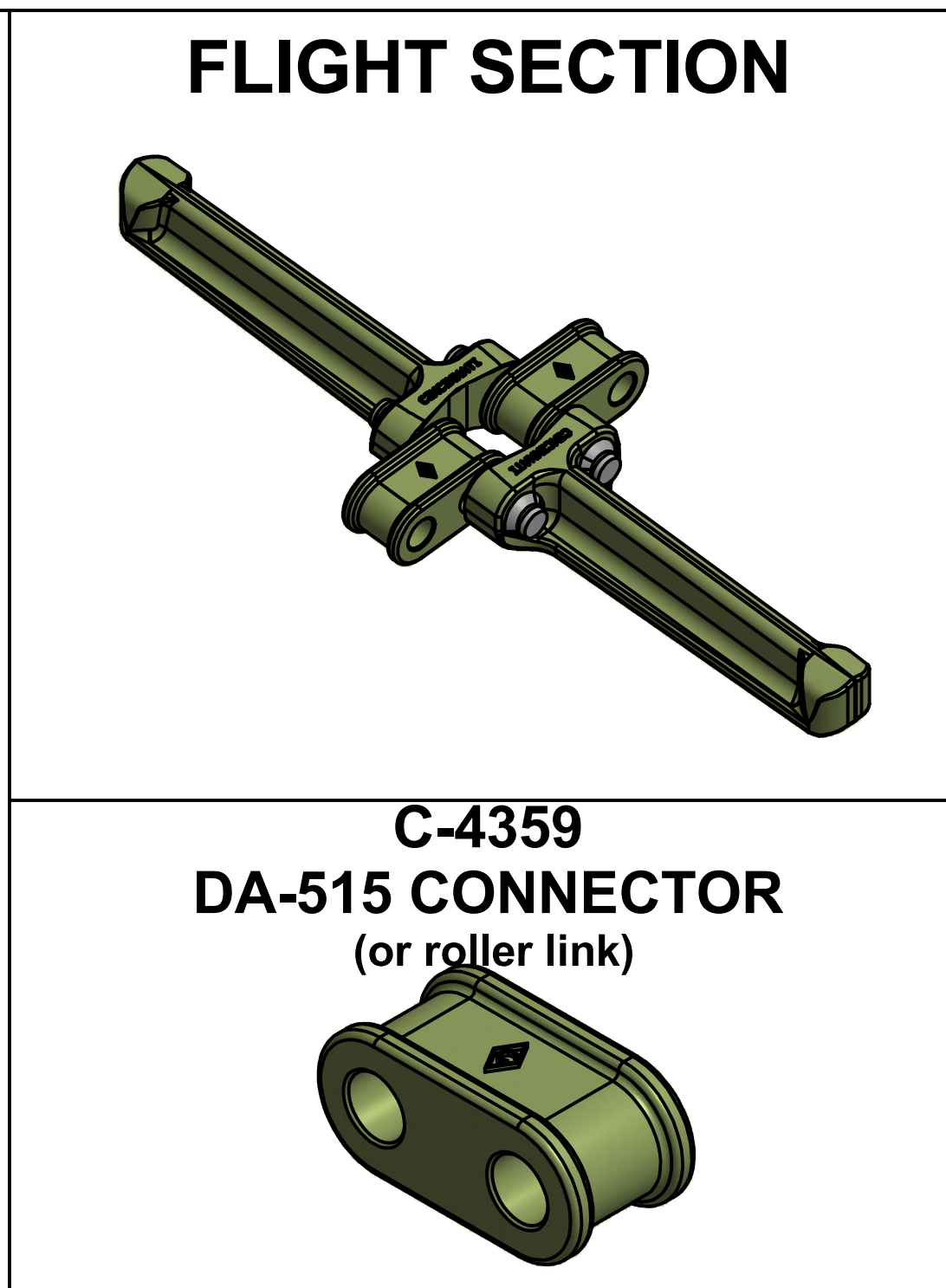
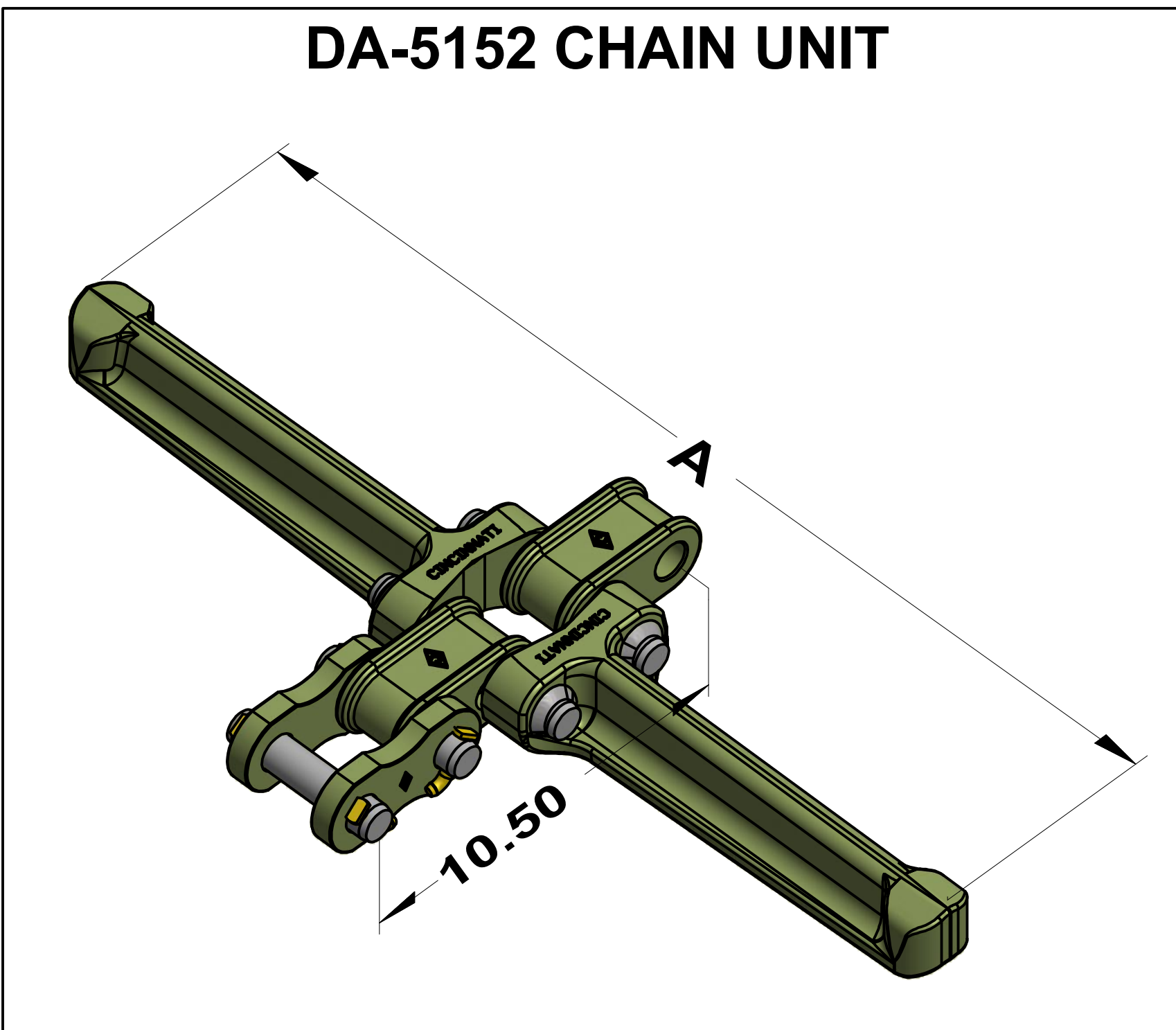

DA-5152 CONVEYOR CHAIN SELECTION CHART

MODEL NO.	*A - WIDTH	CHAIN UNIT	FLIGHT SECTION
DA-5152	27-1/2	C-13638	C-5311

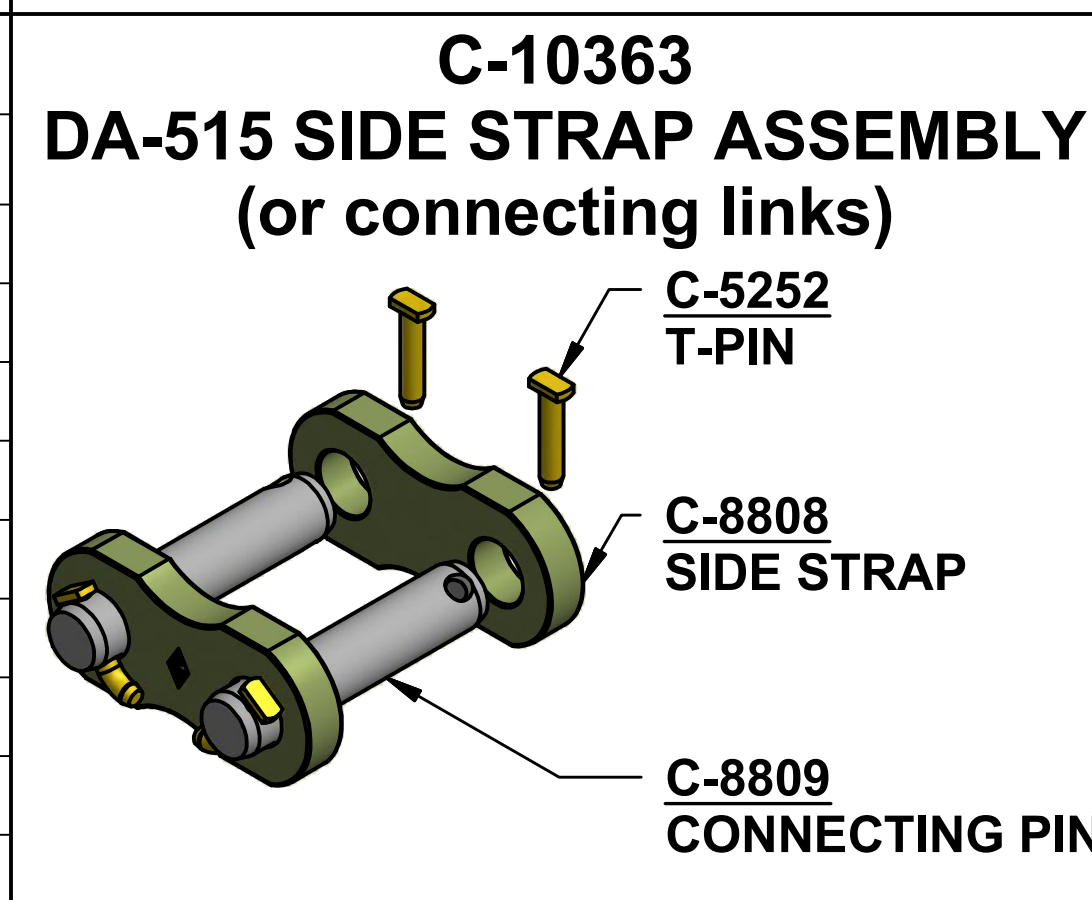

DA-515 CONVEYOR CHAIN SELECTION CHART

MODEL NO.	*B - WIDTH	CHAIN UNIT	FLIGHT SECTION
DA-515	27-1/2	C-8822	C-5311
DA-515-C	26-1/2	C-8825	C-5316
DA-515-E	23	C-8827	C-5808
DA-515-K	22	C-8832	C-6359
DA-515-T	26	C-8839	C-7205
DA-515-Z	29-1/2	C-14472	C-14470

*CHAINS WIDTHS OTHER THAN THOSE LISTED ARE AVAILABLE UPON REQUEST